

MSE Meili

Multiphase Systems Engineering

Technoparkstr. 1 · CH-8005 Zürich · Tel ++41 1 440 55 00 · Fax ++41 1 440 55 04 · info@msemelli.ch

Preparations for 'Labasys 100' Measurements

Probe Tip without Cleaning Unit '16-500' (Ø-tip: 16 mm)

This document is a guide to the preparations necessary for measurements with 'Labasys 100'. The most important parameters of the interface 'Labasys 100' and the customers plant are defined. - Good preparations help to save time and money and are the first step to reliable and accurate measuring results.

1 Preparations & Infrastructure

In general the following items are necessary for measurements with 'Labasys 100' and need to be prepared if not available:

- introduction socket with bush (cf. section 2)
- enough space at the insertion location (cf. figure)
- power supply 230 V / 50 Hz or 110V / 60 Hz
- (roll-) table for measuring-PC ca. 50 x 80 cm
- poss. device for probe support (lab.- boy available)
- if at the measuring point major vibrations are present, we kindly ask you to inform us in advance.
- please inform us about the access to the measuring location in detail (map) - thank you.

2 Introduction Socket

The introduction socket needs to full fill the following requirements:

- holds the instrument in measuring position (weight: ca. 10 kg)
- allows a displacement of the probe during plant operation
- provides sealing in case of pressure differences between process and environment
- Using a ball valve enables the probe introduction into pressurised vessels without operation stop (cf. fig. 1, variant 1): While the valve is closed the probe tip is introduced until the outer O-Ring seals. Then the valve is opened, possibly the drilling purged with a neutral fluid and finally the probe tip introduced completely.

The introduction socket could be supplied by MSE Meili (section 2.1) or could be prepared by the customer itself (section 2.2).

2.1 MSE Meili supplies introduction socket

MSE Meili supplies introduction sockets custom tailored to the customer's plant. Possibly existing introduction socket will be used - the standard solution is shown in fig. 2. For the definition of the optimum introduction solution, we kindly ask you to contact us - thank you.

2.2 Customer provides introduction socket

Based on our experience a design of the introduction socket including a steel flange with a plastic bush inside proved to be well suited. The bush prevents damaging of the probe tip during insertion, decouples the probe from the plant thermally and eases its displacement.

The introduction socket has to support the weight of the probe of approx. 10 kg in extended position reliably and vibration-free. If needed the probe body may be supported by an adjustable device. The **plastic bush** must be designed for the temperatures to be expected (i.e. PTFE) and meet the following measures (cf. fig. 1):

- length: ca. 150 mm (min. 50 mm) - I.D.: 16.2 +/- 0.1 mm
- O.D.: ca. 25 mm with a clearance of 0.1 - 0.2 mm to the introduction socket (thermal expansion!)

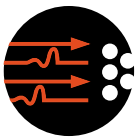

Additional requirements for the **introduction socket**:

- stop ring preventing a displacement of the bush to the inside
- device for axial fixation of the bush / probe
- in case of larger pressure differences (ca. > 10 mbar) O-rings have to be used for sealing (for positioning refer to figure 1)

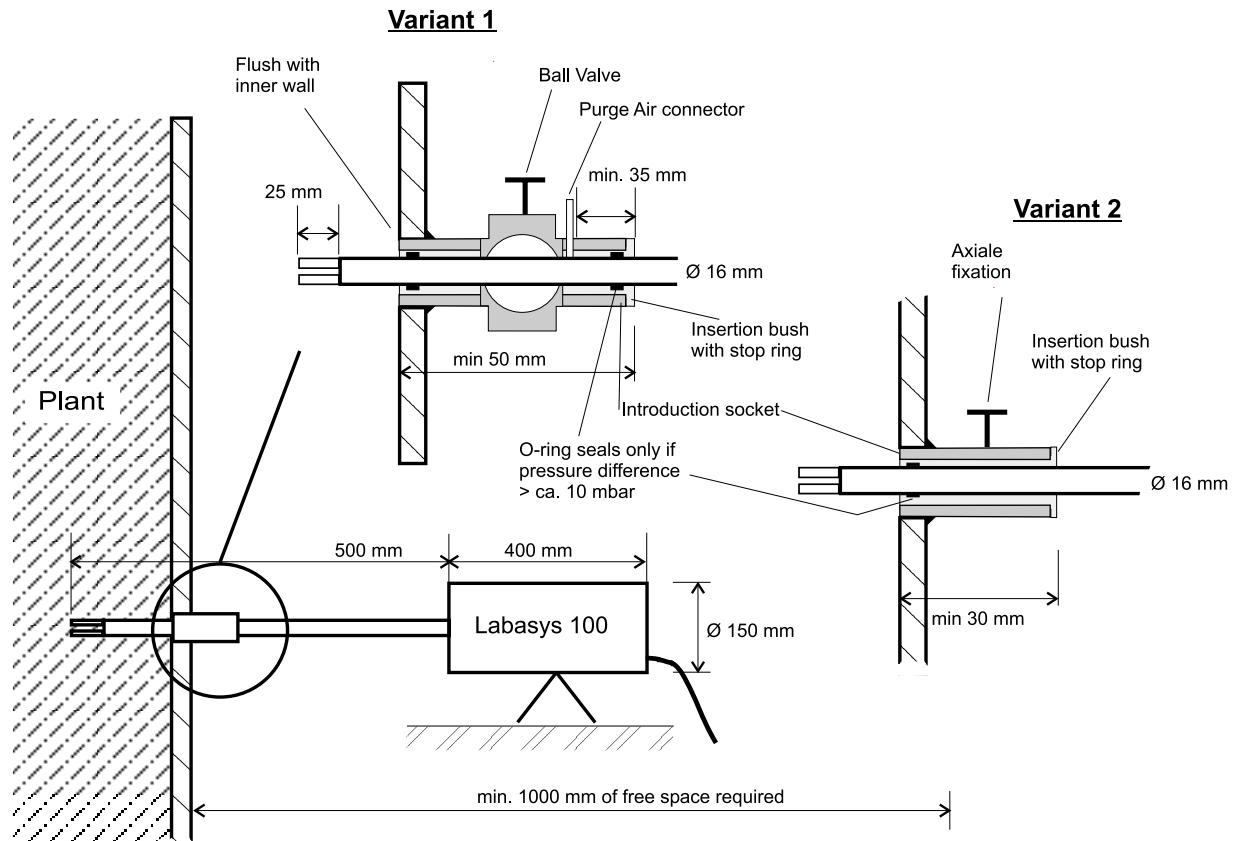

Fig. 1: Principle introduction socket 'Labasys 100 16-500', variants 1 and 2 with and without ball valve.

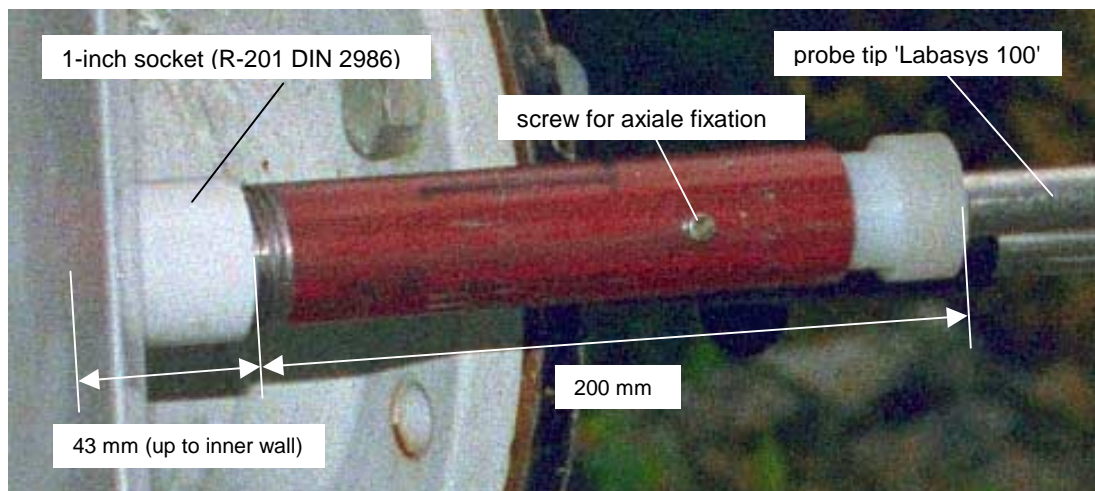

Fig. 2: Standard introduction socket according to variant 2 (figure 1): The customer just needs to prepare 1-inch sockets (R-201 DIN 2986) at measuring spots.

For further questions or problems please feel free to contact us - we are at your disposition!